

ComfortLink™ II Installation Guide

Other Installation Guides may be necessary, based on system configuration. A complete list of other optional components is shown below.



TZONE950AC52ZA

1 Control

2	Relay Panel For use with 24V indoor systems (optional)
3	Zone Panel (optional)
4	Zone Sensor with Display (optional)
5	Zone Sensor (optional)
6	Zone Dampers (optional)

ALL phases of this installation must comply with NATIONAL, STATE AND LOCAL CODES

IMPORTANT — This Document is customer property and is to remain with this unit.

These instructions do not cover all variations in systems or provide for every possible contingency to be met in connection with the installation. Should further information be desired or should particular problems arise which are not covered sufficiently for the purchaser's purposes, the matter should be referred to your installing dealer or local distributor.

Section 1. Safety

⚠ WARNING

This information is intended for use by individuals possessing adequate backgrounds of electrical and mechanical experience. Any attempt to repair a central air conditioning product may result in personal injury and/or property damage. The manufacturer or seller cannot be responsible for the interpretation of this information, nor can it assume any liability in connection with its use.

⚠ WARNING

LIVE ELECTRICAL COMPONENTS!
During installation, testing, servicing, and troubleshooting of this product, it may be necessary to work with live electrical components. Failure to follow all electrical safety precautions when exposed to live electrical components could result in death or serious injury.

Table of Contents

Section 1. Safety	1
Section 2. General Information	2
Section 3. Physical Installation	5
Section 4. Wiring	7
Section 5. Installer Setup	9
Section 6. Advanced Features	13
Section 7. Troubleshooting	17
Section 8. Installer Setup Parameters	18

NOTE: See the User's Guide for wireless setup information.

Section 2. General Information

2.1 Overview

The ComfortLink II Control is a Communicating 7-inch color touch screen that provides an easy-to-use interface to the end user.

The control is a communicating wall mounted control that allows a user to manage an HVAC and zoning system.

With the addition of the 24VAC Relay Panel, conventional HVAC systems can also be controlled.



2.2 Contents in Box

The following parts are included in product model TZONE950AC52ZA:

- 1 - Control
- 1 - Sub-Base
- 4 - SnapSku® Wall Anchors
- 4 - 1" Screws

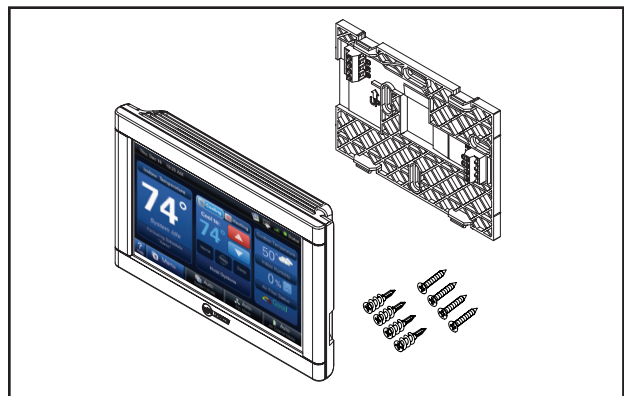

2.3 Specifications

Specification	Description
Product Model:	TZONE950AC52ZA
Product:	ComfortLink II Control
Size:	7.3" width x 4.3" height x 1.2" depth
Storage Temperature	-40°F to 175°F, 5% to 95% RH non-condensing
Operating Temperature:	25°F to 126°F, 5% to 90% RH non-condensing
Input Power:	24 VAC from HVAC System (Range: 18-32 VAC)
Power Consumption:	7 VA*
Wire usage:	Minimum 18 gauge NEC approved control wiring
Zone Sensor Wireless Range (802.15.4):	60 ft. through 3 standard walls
Wireless Connectivity Range (802.11 b/g):	Varies with router model and placement
Communications:	ComfortLink II - 3 wire connection
System Modes:	Heat, Cool, Auto, Emergency Heat
Fan Modes:	On, Auto, Circulate
Cooling Setpoint Temperature Range:	60°F to 99°F, 1°F resolution
Heating Setpoint Temperature Range:	55°F to 90°F, 1°F resolution
Indoor Temperature Display Range:	20°F to 119°F
Outdoor Temperature Display Range:	-31°F to 119°F
Indoor Humidity Display Range:	0% to 99%, 1% resolution
Minimum Cycle Off Time Delay:	Compressor: 5 minutes, Heat: 1 minute

* On every application, 24VAC loads should be reviewed to be sure the indoor unit control power transformer is adequately sized. See the Relay Panel Installer's Guide for guidelines.

2.4 ComfortLink II System Connections

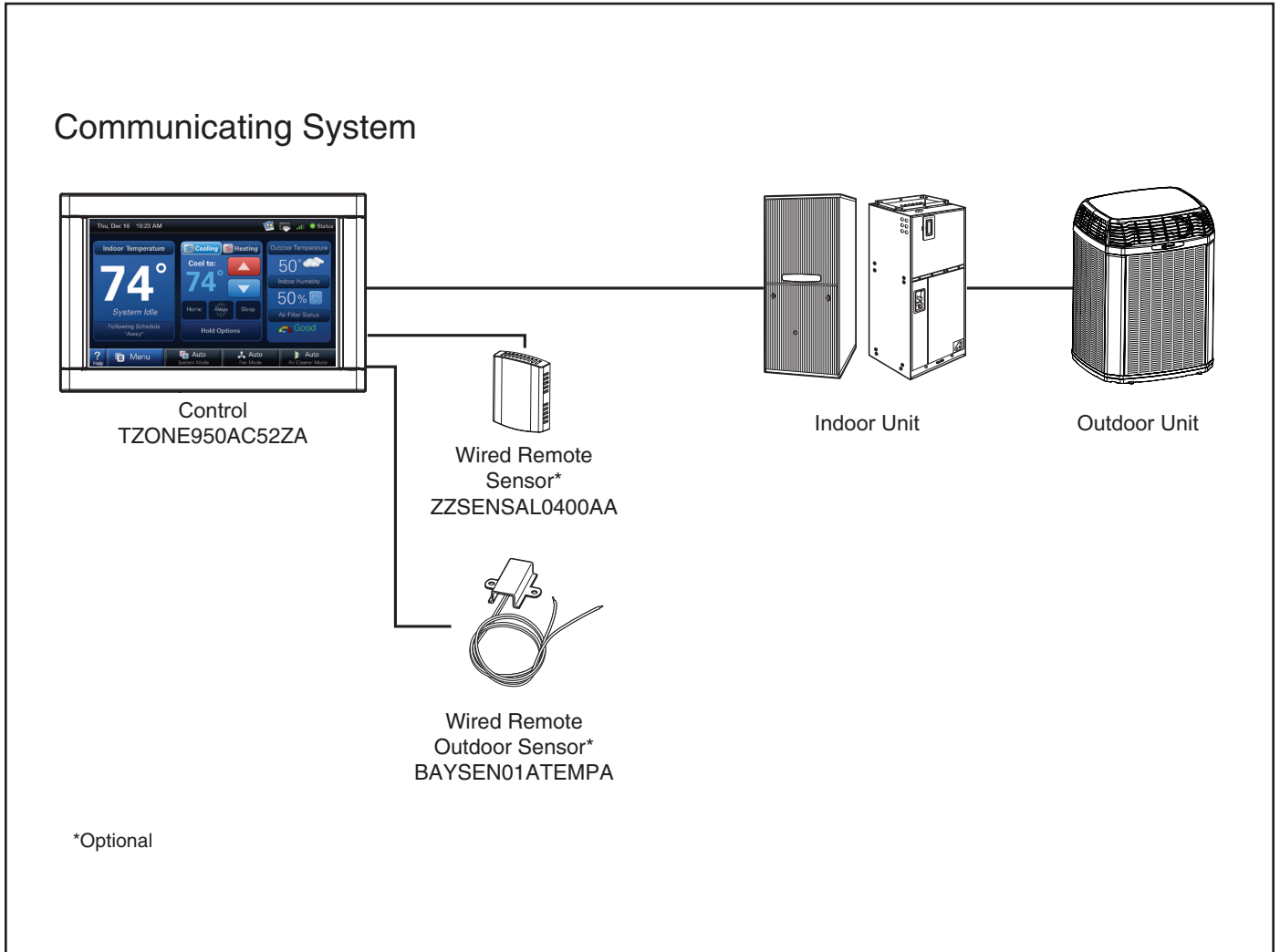

2.4 ComfortLink II System Connections (Continued)

24V System

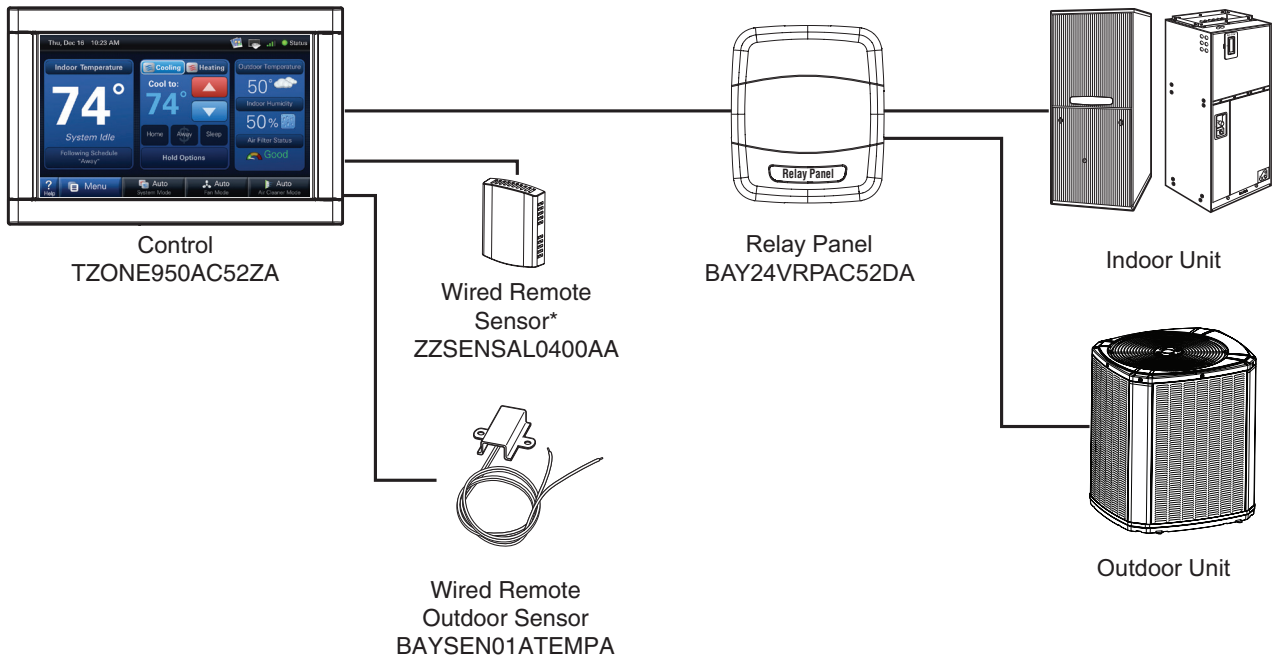

*Optional

Section 3. Physical Installation

1A Temperature Sensing Considerations

The control is designed for installation in climate controlled living spaces. It is recommended to place the unit in central locations with good circulation. Avoid exterior walls and areas near windows, doors, vents or concealed pipes or chimneys.

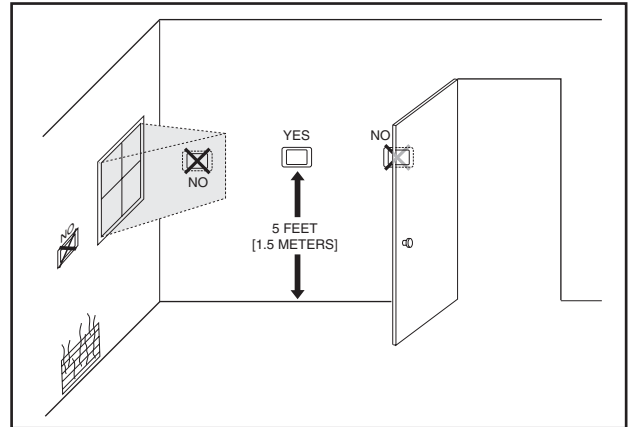

1B Wireless Reception Considerations

If enabling wireless, choose a mounting location that ensures adequate signal strength.

A wireless device may have significantly different signal strengths if its position changes relative to other wireless devices. If the control shows poor signal strength, you may be able to improve the signal strength by moving the control a short distance in any direction.



Considerations to Maximize Signal Strength:

- Do not mount the control **more than 30 feet from the wireless router** (through no more than three interior walls).
- Do not mount the control in areas where **electromagnetic emissions** from other devices, appliances or wiring can interfere with the control's communication. (i.e. wireless phones, security systems, wireless internet cameras)
- Do not mount the control in **recessed areas**, near metal objects, or near structures. (i.e. doors, appliances, entertainment centers or shelving units)
- Do not mount the control closer than **2 inches to any pipes, duct work, or other metal obstructions**.
- Do not have **metal obstructions, concrete or brick walls** between the control and the wireless router it will be connected to.

NOTE: See the User's Guide for wireless setup information (weather, multi-system and remote software update functionality).

2 Removing Sub-Base Wall Plate

Remove sub-base plate from the control by inserting a small flat blade screwdriver into the notch at each of the four tabs as shown.

Gently pry the sub-base away from the the control.

NOTE: This tight fit is normal and ensures that the control is held securely to the sub-base when mounted on the wall.

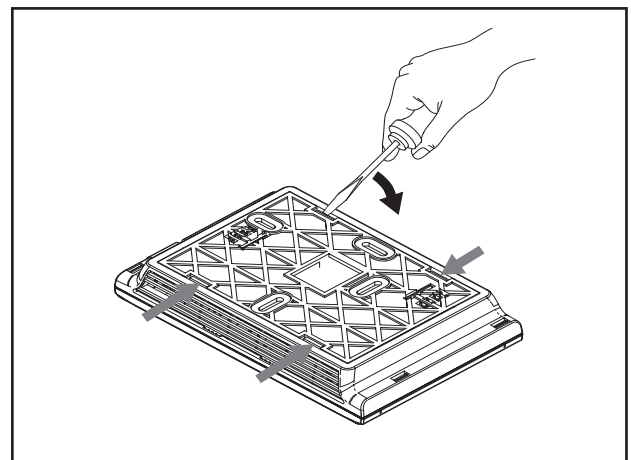

3 Mounting Sub-Base to Wall

Be sure wires are routed through the center of the base plate and are long enough to connect to terminals.

Select and mark three holes.

NOTE: The three hole locations indicated at right are recommended. The top location is an optional mounting screw location.

A level may be used to ensure professional appearance.

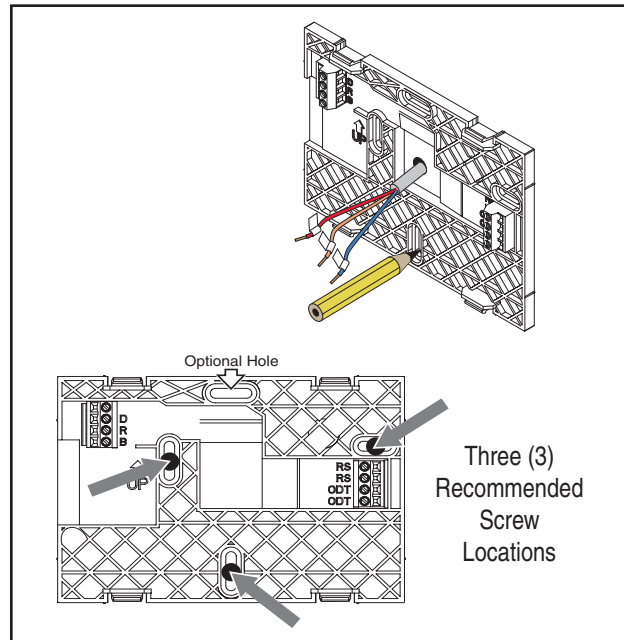

4A Mounting to Studs

Attach base to wall using 3 screws provided. The locations indicated provide the most secure mounting and are recommended.

NOTE: Since moderate force is required when removing the control from the sub-base, the sub-base must be securely attached to the wall.

Do not overtighten screws to avoid damaging the sub-base.

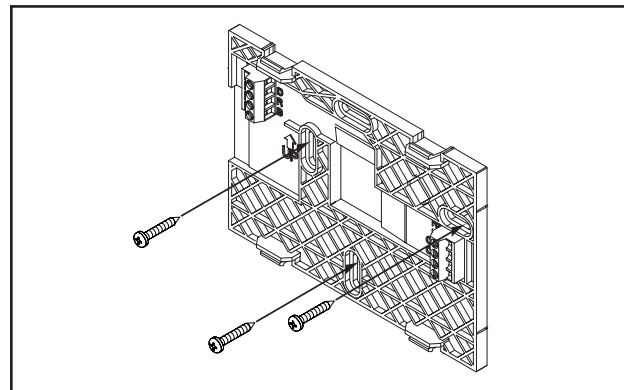

4B Mounting to Drywall

If mounting to drywall, supplied SnapSku® anchors **must** be used to mount the control sub-base to the wall. These anchors will ensure that the control is adequately supported.

NOTE: Since moderate force is required when removing the control from the sub-base, a firmly mounted sub-base is essential.



1) Press tip of SnapSku® anchor into drywall using #2 Phillips screwdriver or screw gun. Drive anchor clockwise into drywall until anchor stops flush with wall.

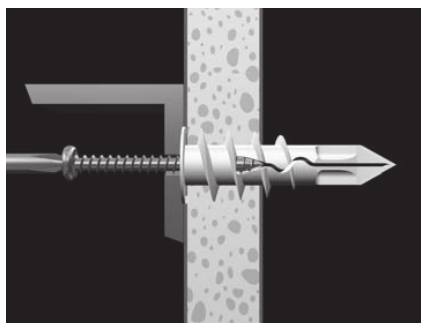

2) Place sub-base over anchor and insert screw.

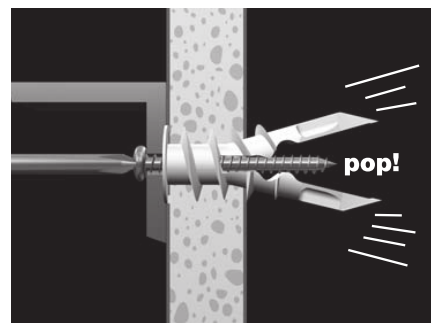

3) Tighten screw flush with sub-base. Screw “pops” open anchor, locking anchor on wall.

Do not overtighten screws to avoid damaging the sub-base.

Section 4. Wiring

⚠ WARNING

LIVE ELECTRICAL COMPONENTS!

During installation, testing, servicing, and troubleshooting of this product, it may be necessary to work with live electrical components. Failure to follow all electrical safety precautions when exposed to live electrical components could result in death or serious injury.

⚠ CAUTION

CAUTION: EQUIPMENT DAMAGE HAZARD - Improper wiring can lead to equipment damage. Follow the terminal connection information carefully to ensure the control is wired properly. After wires are secure, bare wires **MUST NOT** touch each other. See the Field Wiring Diagrams for specific system applications.

NOTE: The maximum total cable length for the entire communicating system is 500 feet 18 AWG. The maximum distance of any single cable from a transformer is 250 feet 18 AWG.

NOTE:

- Use 18-gauge color-coded thermostat cable for proper wiring. Shielded cable is not typically required.
- Keep this wiring at least one foot away from large inductive loads such as Electronic Air Cleaners, motors, line starters, lighting ballasts and large distribution panels.
- Failure to follow these wiring practices may introduce electrical interference (noise) which can cause erratic system operation.
- All unused thermostat wire to be grounded at indoor unit chassis ground only. Shielded cable may be required if the above wiring guidelines cannot be met. Ground only one end of the shield to the system chassis.

5 Power Connections

The control is powered via 24 VAC from the indoor unit. On every application, 24VAC loads should be reviewed to be sure the indoor unit power transformer is adequately sized. The ComfortLink II control draws approximately 4VA more than the typical communicating control.

6 Connect Wiring

Connect wiring to terminals as shown.

Route wiring within the plastic channel as shown so that it does not interfere with control when reinstalling. Do not overlap wires.

Plug the opening with non-flammable insulation to prevent drafts from affecting the control.

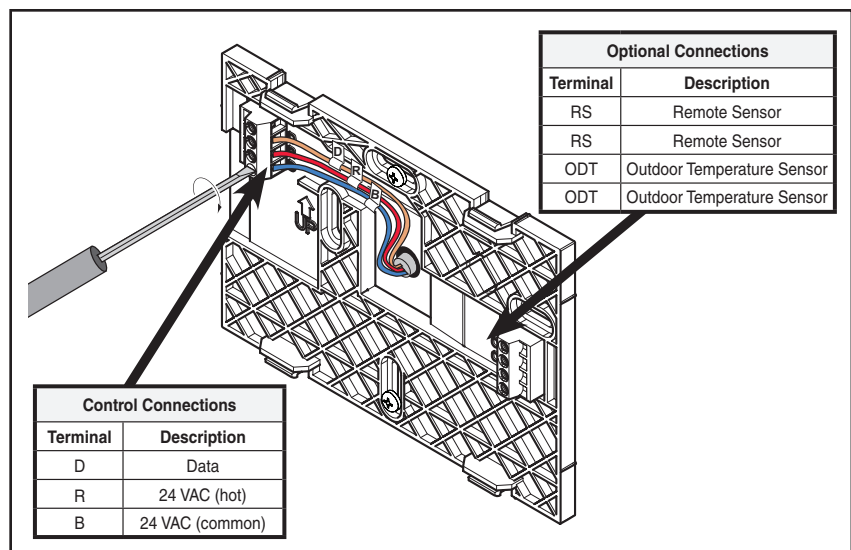

7 Replace Control

Replace unit flat onto sub-base being careful to align unit correctly with the sub-base before applying force.

Control should fit snug and not “rock” when properly installed. Check wire routing if control is unstable.

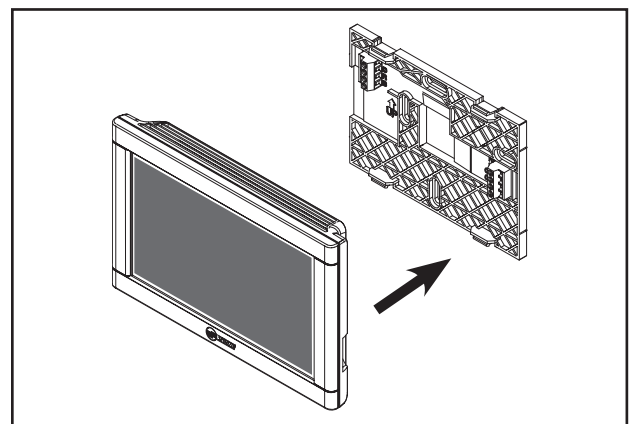

8 Field Wiring

Communicating System



Control

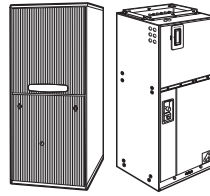

Communicating Indoor Unit

Communicating Outdoor Unit

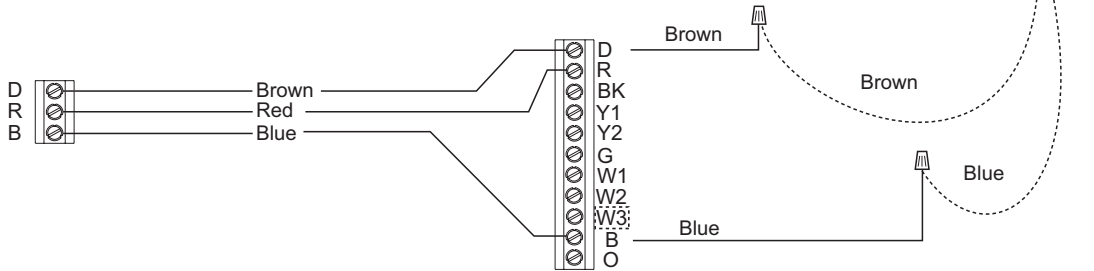
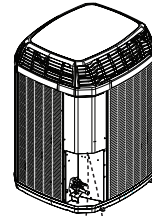

Communicating Indoor with Non-Communicating Outdoor



Control

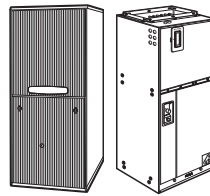

Communicating Indoor Unit

24V Single Stage Cooling

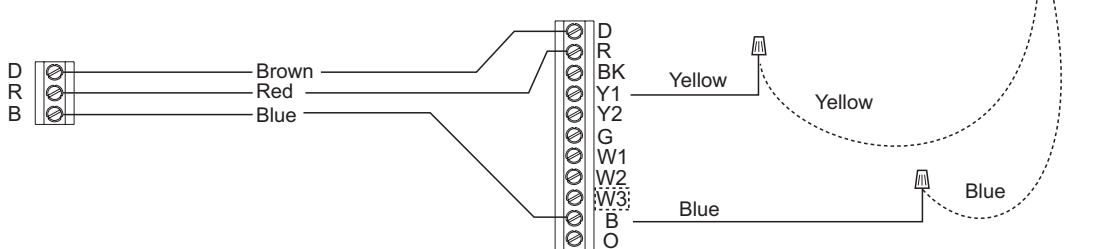
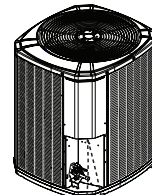

24V System



Control

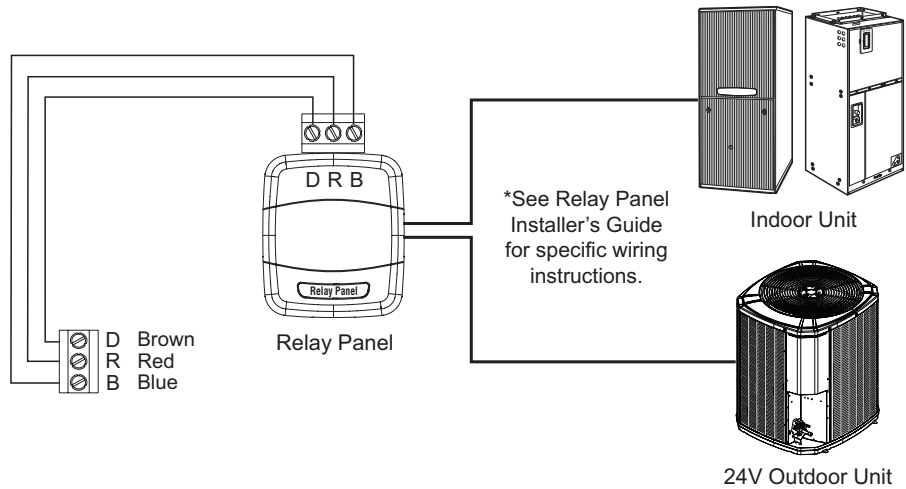

Section 5. Installer Setup

9 Power-Up

Communicating Equipment

Discovery mode begins when the control is first installed and power is connected. For communicating equipment, the control automatically configures standard equipment parameters.

24V Equipment (Using a Relay Panel)

Equipment will need to be configured manually through the Installer's Setup menu in the control. See the following section for more details.

10 Basic Navigation

The home screen displays default temperature settings and parameters.

Pressing a button will display additional information or a new menu screen.



Help: Screens contain a Help button which provides additional information. Screens that are self-explanatory will not list additional help.

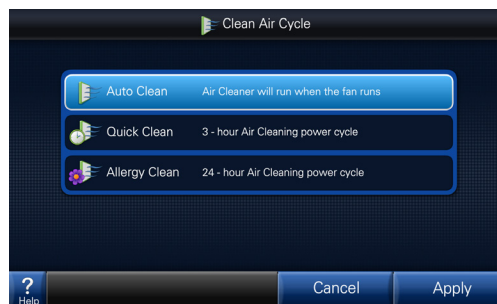

Example (Air Cleaner Mode): Pressing the “Air Cleaner Mode” button on the home screen allows selection of options from a list.

Example (Menu): Pressing the “Menu” button on the home screen shows additional icons to adjust settings.

Buttons shown will vary depending on system type and configuration.

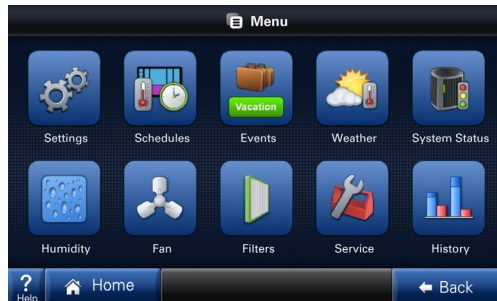

11 Installer Setup Menu

Enter the **Installer's Setup** screen by navigating to:

Home screen --> Menu --> Service --> Technician Access --> Proceed --> Installer Setup*

***NOTE:** Press and hold the "Technician Access" button for 5 seconds to enter the **Service Menu** screen.

NOTE: See Section 8 for a complete list of menus and parameters that can be set in the **Installer Setup** menus.



11A Installer Setup Menu - Standard

Standard

Pressing the “Standard” button allows manual selection and configuration of basic equipment components.

NOTE: In a communicating system, components will be discovered automatically so this manual setup is not required.

Example:

The “Standard” screens allows selection of non-communicating equipment.

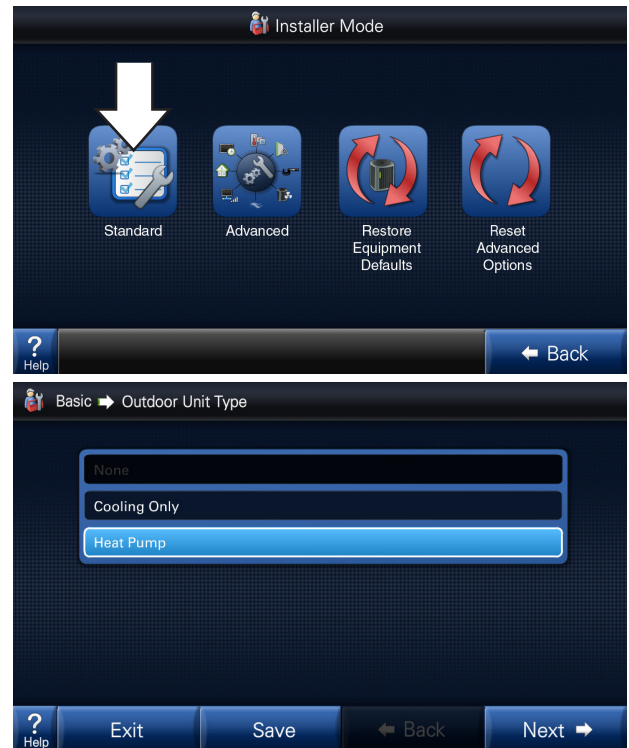

11B Installer Setup Menu - Advanced

Advanced

Equipment settings may be adjusted to alter the default settings to fine-tune a system’s operation.

Installed accessories and comfort options may be configured in the Advanced screen.

NOTE: Icons available in this menu will vary based on equipment configuration.

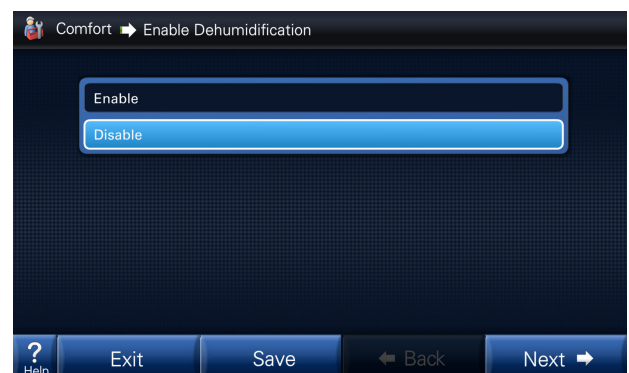

Example:

Press the “Comfort” button to enable or disable comfort settings such as dehumidification (at right).

11C Installer Setup Menu - Restore Equipment Defaults

CAUTION: “Restore Equipment Defaults” returns the control to factory settings. **ALL** settings and data will be lost.



11D Installer Setup Menu - Reset Advanced Settings

“Reset Advanced Settings” resets the **Advanced** Settings which were configured in the Installer Menu (settings such as system lockouts, accessories, air flow and comfort options).



12 Wireless Networking

NOTE: See the control's User's Guide for wireless setup information.

Section 6. Advanced Features

Feature	Description
1-Touch Presets	The 1-Touch Presets allows for an immediate change to the setpoint status. Set the desired temperature for the three status modes (Home, Away & Sleep). The control will remain in the selected mode until another mode is selected or the program reaches a new schedule period.
Aggressive Recovery	<p>Aggressive Recovery: This option disables the 10 minute inhibit anytime the control sees more than a 2° change (such as moving from one program time frame to another). This applies to heating & cooling modes.</p> <p>Heating Aggressive Recovery: This option disables the 10 minute inhibit based on outdoor temperature in heating mode only. The value for outdoor temperature can be set from 0°–70°.</p> <p>Heating Aggressive Recovery can only be enabled if Aggressive Recovery is disabled.</p> <p>There is a 10 minute “inhibit” period between first and second stage compressor as well as compressor heating & supplemental strip heat. This 10 minute inhibit period minimizes the cycling of higher capacity request due to drafts around the control or marginal load conditions.</p>
Air Cleaner Mode	There are three options when setting the Air Cleaner Mode: Auto--the air cleaner will run whenever the blower is running. Quick Clean--the control will energize the air cleaner at 100% output and blower at 100% air flow for a 3-hour run cycle. Allergy Clean--the control will energize the air cleaner at 100% output and blower at 100% air flow for a 24-hour cycle.
Alert Indication	<p>System alerts will be indicated on the home screen of the control with two options: “Close” or “Dealer Contact Information”.</p> <ul style="list-style-type: none"> • Selecting “Dealer Contact Information” will display the dealer screen. • Selecting the “Close” option will move the alert to the top right corner of the home screen. Pressing the icon button in the top right corner of the screen will recall the alert to the home screen. <p>All alerts will remain until resolved.</p> <p>Critical Alert – indicates the loss of heating or cooling operation. Only critical alerts will be displayed on the home screen. These alerts will flash red when “closed” and moved to the top right corner of the control.</p> <p>Major Alerts – indicates the loss of system functionality, but the system is still operational. Major alerts will be displayed as a solid yellow icon in the upper right corner of the control.</p>
Backlight	The backlight of the control will increase anytime the screen is pressed (active mode) and dim after a time period of non-activity (standby mode). This timeout period between active mode and standby mode can be customized from 5–60 seconds.
Blower On / Off Delays	Blower on / off profiles can be set independently for heating and cooling modes. There are blower delays specific for variable speed, non variable speed and hydronic heat applications.
Brightness	The brightness of the screen can be customized for viewing preferences. Screen brightness can be set for daytime and nighttime modes. The Ambient Light Setting icon sets the amount of room light required to shift the display between daytime and nighttime settings.
Calibration	The sensors (indoor, remote and outdoor) can be individually calibrated for temperature and humidity. The indoor sensors may be calibrated to plus or minus 5° or 5% humidity in increments of 1 . The outdoor sensor may be calibrated to plus or minus 10° in 1° increments.
Control Response Rate	This feature changes the response rate of the control. Selecting a “faster” response rate will maintain a tighter tolerance of indoor temperatures, but increases the cycling of the system.
Customizable Home Screen	Options such as screen brightness, screen savers, background colors, screen calibration and customized shortcuts can all be modified to create a personalized home screen.

Feature	Description
Cycle Rate	<p>The cycle rate affects the cycle time of the system. With a 50% load value, a cycle rate of 3 will allow the system to run for 10 minutes and be off for 10 minutes; completing 3 cycles in one hour. A cycle rate of 5 would allow the system to cycle on and off at 6 minute intervals. The higher the cycle rate, the more often the system turns on and off.</p> <p>The actual amount of time the system will be “on” or “off” will be reflective in the load value of the home. Higher load value demands will increase system run time and decrease system off time. Lower load value demands will decrease system run time and increase system off time.</p>
Dealer Information	<p>Dealer contact information, including name, address, website and multiple phone numbers may be entered. In addition, a dealer logo (which must be named dealer.jpg) can be uploaded through the use of an SD card. File size should not exceed 3 MB.</p>
Dehumidification	<p>There are two requirements before dehumidification is enabled:</p> <ul style="list-style-type: none"> • Dehumidification must be enabled through the Installer Setup. • The indoor relative humidity must be above the desired setpoint. <p>The system will take the following actions once this condition is met:</p> <ul style="list-style-type: none"> • The blower will reduce air flow proportional to the amount of RH error. The control evaluates the percentage of humidity error and how long the error has existed to determine the amount of air flow reduction, up to 30% reduction. • If overcooling is enabled, the control will engage a 1 degree of overcooling for each 10% of RH error. A maximum amount of overcooling can be configured to 1, 2 or 3 degrees. • Fan off delays will be eliminated. <p>Smart Continuous Fan Continuous fan operation will be interrupted when indoor relative humidity exceeds desired humidity setpoint. A humidity icon will be displayed along with the fan icon to indicate that blower on options have been disabled due to high humidity conditions. Smart Continuous Fan will not interrupt the fan circulate mode.</p>
Diagnostics	<p>Diagnostics are displayed as current alerts (what is currently happening in the system) and alert history (what has occurred in the past, but are no longer present). The alert screen describes the alert, when the alert happened, the severity level of the alert as well as a problem description and possible causes to assist with troubleshooting. Up to the last 30 days are displayed.</p>
Dual Fuel Options	<p>The change over from heat pump to furnace can be set based on three options:</p> <ul style="list-style-type: none"> • Comfort—This is strictly based on indoor temperature demand. The furnace will take over when the heat pump can no longer maintain the indoor heating demand. • Operating Cost—The HSPF of the heat pump and AFUE of the furnace must be entered along with cost of electricity and fuel. The control calculates an economic balance point for system change over. • Outdoor Temperature—The changeover from heat pump to furnace is based on outdoor temperature which can be set from 0–70° (thermal balance point). <p>The furnace will take over anytime the HP is unable to maintain indoor temperature, regardless of the dual fuel option chosen.</p>
Emergency Heat	<p>The heat pump will be disabled and the furnace / heat strips are enabled any time the control is set to Emergency Heat.</p>
Equipment List	<p>This lists the model and serial number for all communicating components. The model and serial numbers for non communicating components can be manually entered.</p>
Fan Options	<p>There are three options available for blower operation:</p> <ul style="list-style-type: none"> • Auto—the blower runs when there is a call for cooling or heating. • On—the blower will run continually with a fan only call. The continuous fan speed for variable speed motors can be adjusted from 35%–100%. A call for heating or cooling will supersede a fan only call and the blower will run at a speed that matches the staging of the equipment. • Circulate—this provides all the features of “fan on”, but the blower will only run a percentage of the time when there is no call for heating or cooling. The blower can be set to circulate from 10–55 minutes of every hour.
Help Screens	<p>The bottom left corner of all screens has a Help icon with a question mark. This icon provides assistance for the screen that is currently being displayed. Screens that are self explanatory will not list additional help. Pressing the Help icon on these screens will display “No additional help available”.</p>
History Runtime	<p>The History Runtime screen provides information on system run time in comparison to the indoor and outdoor temperatures (average indoor along with the high & low outdoor temps). This history can be displayed on a weekly or monthly basis.</p>

Feature	Description
History Screen	The History Screen provides system cycle information. Cycle counts and run time can be viewed for first stage and second stage compressor operation, W1 & W2 heating and defrost cycles. This information can be viewed in a 24 hour, 1 week or 2 week period.
Humidification	<p>There are two options available for humidification:</p> <ul style="list-style-type: none"> • Indoor RH setpoint—this controls the humidifier based on the desired indoor humidity setpoint (options from 10%–45%). • Frost Control setpoint--The control references the outdoor temperature and indoor environment to calculate the risk of frost or condensation on interior walls and windows. A scale of 0 to 10 allows for customized settings based on the insulation properties of the home. A higher number may be selected for well insulated homes, whereas a lower number should be selected on poorly insulated homes. A lower number should be utilized if condensation is observed. <p>There are two control options for enabling humidification:</p> <ul style="list-style-type: none"> • Humidification with an active call for heat. • Humidification without an active call for heat (control energizes blower and humidifier). <p>Humidification is only available when in the heating mode (or in the auto mode when the last call was for heating). A 60 second minimum blower off delay is enforced if “steam” humidification is selected.</p>
Installer Setup	<p>There are two categories for Installer Setup.</p> <ul style="list-style-type: none"> • Standard—this is the basic system settings such as heat pump or cooling only, single or multi stage, compressor type, etc. This is the basic system set up that is self discovered in communicating mode, but requires manual input when using a Relay Panel for 24 volt configurations. • Advanced—this provides advanced configuration of the system such as cycles per hour, minimum run times, humidification and dehumidification setpoints, blower delays and temperature lockouts to name a few of the customizable features in this set up.
Load Value	Load Value is a numerical representation of the needed capacity to satisfy the setpoint. Proportional (distance from setpoint) error plus integral (time away from setpoint) error is used to calculate load value.
Lockouts	<p>System lockouts will disable a certain function of the system under specific outdoor temperatures:</p> <ul style="list-style-type: none"> • Compressor Heating Lockout – will lockout all compressor operation below a set outdoor temperature (from 5°–70°). This value must be set lower than the auxiliary heat lockout. • Auxiliary Heating Lockout – will lock out auxiliary heat stages above a set outdoor temperature (from 40°–70°). This value must be set higher than the compressor heating lockout. • Defrost Heater Balance Point for W1, W2 & W3 – will lock out specific auxiliary heat stages when above a set outdoor temperature. (W1 setpoint is from 40°–55°, W2 & W3 setpoints are from 5°–55°). This feature does not apply to dual fuel systems. • Compressor Cooling First Stage Lockout – will lock out the first stage compressor above a set outdoor temperature. (from 80°–120°) • Compressor Heating First Stage Lockout – will lock out the first stage compressor below a set outdoor temperature. (from 0°–50°) • Furnace First Stage Heating Lockout – will lock out first stage furnace operation below a set outdoor temperature. (from 15°–50°) <p>First stage lockouts are not available with zoning.</p>
Multi Systems	Multiple controls that manage individual systems can be linked. Multiple systems can be managed from any control location. A wireless home network is required for multi system functionality.
Photo Album	Allows the customization of a photo album screen saver. An SD card is required to view the pictures. Photos may be in .jpg, .jpeg, .bmp, .png, or .gif file formats and must be smaller than 3 MB each.
Reminder Screens	Reminders can be set for filters, UV lamps, humidifier pads, and various other service reminders.
Restore	<p>There are three levels of restore:</p> <ul style="list-style-type: none"> • Restore from the Setting Screen – this restores all personal configurations, such as program schedules and home screen customization to their default setting. • Reset Advanced Options from the Install Set Up screen – this restores all the advanced set up selections such as system lockouts, accessories, air flow and comfort options to their default setting. • Restore Equipment Default – this restores the control to its “out of the box” condition. All settings will be set to their factory default condition.
Runtime History	The History Runtime screen provides information on system run time in comparison to the indoor and outdoor temperatures (average indoor along with the high & low outdoor temps). This history is displayed on a weekly or monthly basis.

Feature	Description
Scheduling	<p>Allows for 7 day programming with one to six scheduled time periods per day. There are two options available for setting a schedule:</p> <ul style="list-style-type: none"> • Guided Setup – a step by step interactive process for setting up a schedule. • Manual Setup – a direct modification to an existing schedule which skips the interactive set up wizard from the guided set up. <p>Scheduling is not required. The control can operate as a non programmable control.</p>
Screen Cleaning Mode	<p>The Clean Screen Mode creates a 30 second screen lockout. The screen can be touched and cleaned without changing settings. There is an icon “Press and Hold to Exit” which will exit this mode if necessary--eliminating the 30 second lock out.</p>
Screen Layout	<p>The Screen Layout icon allows for customization of what is displayed on the home screen.</p>
SD Card Logging	<p>The control has the ability to log all information to a SD Card. A typical 24 hour log will consist of 12 to 20 megabytes of information. The control will overwrite the oldest data once the card becomes full.</p>
Security	<p>Security initiates a keypad lockout. The control can only be accessed by a four digit pass code which can be configured in two different formats:</p> <p>Pin Lock: When the Pin Lock is selected, the control is completely locked. The user will need to enter a four digit password to change any setting (the default is “1234”).</p> <p>Guest mode: The enabling of this mode allows a guest to change the temperature up to 5° in either direction from setpoint and access to the weather, but cannot change the mode or any customized settings.</p>
Setpoint Dead Band	<p>This sets the temperature band between heating and cooling setpoints while in the auto mode.</p>
Software Updates	<p>The control is field software upgradable. Insert a SD card and press the Software Update icon, and updates will begin automatically.</p>
Stage Inhibit	<p>To prevent the next stage of capacity from being initialized, when the current capacity stage will satisfy the load a stage inhibit function is utilized.</p>
System Report	<p>The System Report Screen provides a real time in depth look at operating conditions. While similar to the System Status screen, the system report adds additional information for service technicians.</p>
System Status	<p>The System Status screen shows the snapshot of what the system is doing; including system mode, air flow percentage and reminders.</p>
System Test	<p>The System Test feature allows a technician to lock the system into a particular mode of operation for up to 30 minutes.</p>
Technician Access Screens	<p>The “Technician Access” icon has a 5 second hold delay to enter the technician service screens. After this 5 second hold delay, the technician will see a “Caution!” screen noting that only a trained HVAC technician should proceed into this area.</p>
Vacation Mode	<p>Through an interactive calendar, pick the date, time and temperature to begin and end a vacation set back period.</p>
Warm Air Discharge	<p>Enabling Warm Air Discharge will reduce the variable speed blower air flow by 20% when in compressor heating operation. Warm air discharge only applies to compressor heating and is disabled when hydronic, fossil fuel or electrical heat (including supplement heat) modes are activated.</p>
Weather	<p>The Weather feature displays the outdoor temperature, 5-day forecast and local Doppler radar. The weather screen is available once Wireless Service to the internet and Remote Services are enabled.</p>

Section 7. Troubleshooting

Symptom	Possible Causes	Action
Control displays an alert code on the screen.	Alert Code is present.	Refer to the Alert Code Addendum. Check the Alert icons in the diagnostic screen.
Display will not come on	Loss of 24VAC between R & B at the control.	1) Check wiring between R & B to see if R & D, or B & D have been reversed. 2) Check transformer for 24VAC output. 3) Check for broken or shorted thermostat wire.
Indoor temperature display is incorrect.	Indoor temperature display needs calibration.	Calibrate temperature sensor from control menu.
Indoor humidity display is incorrect.	Indoor humidity display needs calibration.	Calibrate humidity sensor from the control menu.
Room temperature overshoots when the Heat/Cool setting is changed more than 2°.	1) Oversized heating/cooling equipment under current conditions. Control cannot respond fast enough to prevent overshooting. 2) Improper location of control. 3) Aggressive recovery is activated.	1) Compare heat load calculation to equipment chosen. 2) Relocate control (or use remote sensor) if control is in "dead" spot (poor or no air circulation). 3) Deactivate aggressive recovery.
Heating will not come on.	1) System mode is not set to Heat/Auto or setpoint is set too low. 2) Minimum off time delay is being enforced. 3) Heating system may require service.	1) Set mode to heat and raise the setpoint above the room temperature. 2) Wait for 5 minutes and recheck heating equipment. 3) Check/repair system.
Cooling will not come on.	1) System mode is not set to Cool/Auto or the setpoint is too high. 2) Minimum off time delay is being enforced. 3) Cooling system may require service.	1) Set mode to cool and lower the setpoint below the room temperature. 2) Wait for 5 minutes and recheck cooling equipment. 3) Check/repair system.
Heating or Cooling is displayed, but no warm or cool air is coming from the registers.	1) There is a fan delay as the heating or cooling equipment turns on. 2) Equipment is not working properly.	1) Wait a minute for blower delays and recheck registers. 2) Check/repair system.
Fan runs all the time	1) Fan mode is set to On, Circulate or Clean mode 2) There is a failure in the indoor unit	1) Check control settings to see if fan is set to On, Circulate or Clean mode. 2) Check indoor unit for failures (such as tripped heating limit).
Fan is set to ON but not running.	1) Humidity control is engaged. 2) Blower motor is not functioning.	1) If indoor humidity is higher than desired setpoint, the blower will cycle off with the equipment. 2) Check/repair system.
Cooling or Heating cycles too fast or too slow (narrow or wide temperature swings).	1) Check the location of the control for drafts. 2) Cycles per hour or aggressive recovery is improperly set.	1) Seal all air leaks behind control. Relocate control or apply remote indoor temperature sensor. 2) Adjust cycle rates and aggressive recovery features in the advanced installer set up.
Heat pump is not turning on; only furnace or electric heat strips are running.	1) Outdoor temperature is below compressor lockout temperature setting. 2) Compressor heating lockout is enabled and outdoor temp sensor is out of calibration or failed.	1) Adjust the compressor lockout temperature setting if desired. 2) Check/repair outdoor sensor or wiring.
Cannot change system mode to desired setting.	Equipment is not configured properly.	Check the standard installer set up screen to ensure equipment is properly configured.
Screen does not respond properly to a button press	Screen is out of calibration	Remove control from sub base and reset. Follow the calibration instructions when the control reboots.
"No System Found" displayed on the control	Internal error	Reboot the control via onscreen button.
Slow or no response to any button presses	Internal error	Remove the control from the sub base and reset.

Section 8. Installer Setup Parameters*

*Each **Bold** heading below corresponds to a menu in the Installer Setup. All possible options are shown for the menu and each submenu. Selections shown in any particular system will be dependent on system type and configuration.

Standard

Outdoor Unit Type	None	Cooling Only	Heat Pump		
Outdoor Unit Stages	1	2			
Compressor Type	Single Compressor	Two Compressor			
Indoor Unit Type	Two Stage	Two Stage		Hydronic	
Indoor Unit Heat Stages	None	1	2	3	Modulating
Indoor Unit Blower Type	Variable Speed	Non Variable Speed			

Advanced

Equipment

Compressor Cooling Cycles Per Hour	2	3	4	5	6
1st Stage Compressor Heating Cycles Per Hour	2	3	4	5	6
2nd Stage Compressor Heating Cycles Per Hour	2	3	4	5	6
Compressor Heating Cycles Per Hour	2	3	4	5	6
1st Stage Compressor Cooling Cycles Per Hour	2	3	4	5	6
2nd Stage Compressor Cooling Cycles Per Hour	2	3	4	5	6
Compressor Minimum On Time - Minutes	3				
1st Stage Compressor Minimum On Time - Minutes	3				
2nd Stage Compressor Minimum On Time - Minutes	3				
Indoor Heater Cycles Per Hour	2	3	4	5	6
1st Stage Indoor Heater Cycles Per Hour	2	3	4	5	6
2nd Stage Indoor Heater Cycles Per Hour	2	3	4	5	6
3rd Stage Indoor Heater Cycles Per Hour	2	3	4	5	6
Indoor Heater Minimum On Time - Minutes	1				
1st Stage Indoor Heater Minimum On Time - Minutes	1				
2nd Stage Indoor Heater Minimum On Time - Minutes	1				
3rd Stage Indoor Heater Minimum On Time - Minutes	1				

Sensors

Select Outdoor Temperature Sensor	None	Sensor Wired to Control	CLII/ AccuLink Outdoor Sensor	Sensor Wired to Relay Panel
Calibrate Outdoor Temperature Sensor - Degrees	+/- 5 increments			
Calibrate Indoor Temperature Sensor - Degrees	Zone x +/- 5 increments			
Calibrate RH sensor	Zone x +/- 5 increments			

Accessories

Filtration Type Installed	Comm Air Cleaner Discovered	Air Cleaner	Media Filter
Number of Air Cleaners Installed	1	2	
Humidifier Installed	Yes	No	
Humidifier Type	Steam	Bypass/Powered	
Humidifier Control	RH Control	Frost Control	
Humidifier Control Option	Humidify with Active Heat Call	Humidify without Active Heat Call	
UV Light Installed	None	Yes	
ERV Installed	None	Yes	

Comfort

Enable Dehumidification	Disable	Enable		
Dehumidification Overcooling Limit - Degrees	0	1	2	3
Control Response Rate	Normal	Fast		
Aggressive Recovery > 2° Setpoint Change	Disable	Enable		
Heating Aggressive Recovery	Disable			
Heating Aggressive Recovery - Outdoor Temperature	0 to 70			

Warm Air Discharge	Disable	Enable
--------------------	---------	--------

Airflow

VS Blower On Delay - Cooling	No Delay
	1 Minute @ 50%, 7.5 Minutes @ 80%
	1 Minute @ 50%, 4 Minutes @ 80%
	7.5 Minutes @ 80%
	4 Minutes @ 80%
	1 Minute @ 50%
	30 Seconds @ 35%
VS Blower Off Delay - Cooling	No Delay
	1.5 Minutes @ 100%
	45 Seconds @ 100%
	30 Seconds @ 50%
	1.5 Minutes @ 50%
	3 Minutes @ 50%
	30 seconds @ 35%
VS Blower On Delay - Compressor Heating	No Delay
	1 Minute @ 50%, 7.5 Minutes @ 80%
	1 Minute @ 50%, 4 Minutes @ 80%
	7.5 Minutes @ 80%
	4 Minutes @ 80%
	1 Minute @ 50%
	30 Seconds @ 35%
VS Blower Off Delay - Compressor Heating	No Delay
	1.5 Minutes @ 100%
	45 Seconds @ 100%
	30 Seconds @ 50%
	1.5 Minutes @ 50%
	3 Minutes @ 50%
	30 seconds @ 35%

Non VS Blower On Delay - Cooling (Seconds)	No Delay	15	30	90
Non VS Blower Off Delay - Cooling	No Delay	30	60	90
Non VS Blower On Delay - Compressor Heating	No Delay	15	30	
Non VS Blower Off Delay - Compressor Heating	No Delay	30	60	90
Hydronic Heat Blower On Delay	No Delay	30	60	
Hydronic Heat Blower Off Delay	No Delay	30	60	90
Compressor Low Stage Air Flow % - Cooling	35-60	55-80		
Compressor Low Stage Air Flow % - Compressor Heating	35-60	55-80		

Lockouts

Compressor Heating Lockout	Disable	Enable
Compressor Lockout - Outdoor Temperature	5 - 70	
Auxiliary Heat Lockout	Disable	Enable
Auxiliary Heat Lockout - Outdoor Temperature	40 -70	
Defrost Heater Balance Point (W1)	Disable	Enable
Defrost Heater Balance Point (W1) - Outdoor Temperature	40 - 55	
Defrost Heater Balance Point (W2)	Disable	Enable
Defrost Heater Balance Point (W2) - Outdoor Temperature	5 - 55	
Defrost Heater Balance Point (W3)	Disable	Enable
Defrost Heater Balance Point (W3) - Outdoor Temperature	5 - 55	
Compressor Cooling 1st Stage Lockout	Disable	Enable
Compressor Cooling 1st Stage Lockout - Outdoor Temperature	80 - 120	
Compressor Heating 1st Stage Lockout	Disable	Enable
Compressor Heating 1st Stage Lockout - Outdoor Temperature	0 - 50	
Furnace Heating 1st Stage Lockout	Disable	Enable
Furnace Heating 1st Stage Lockout - Outdoor Temperature	0 - 50	



TRANE®

6200 Troup Highway
Tyler, TX 75707
© 2011 Trane



The manufacturer has a policy of continuous product and product data improvement and it reserves the right to change design and specifications without notice.

Representative-only illustrations included in this document.